



2-PC. SCREWED END BALL VALVE 2006WB



FEATURES

- Full port
- W.P. : 1/4"~1" - 2000 WOG(PN150)
1-1/4"~2" - 1500 WOG(PN100)
2-1/2"~4" - 1000 WOG(PN63)
- W.T. : -20°C~200°C (-4°F~392°F)
- Investment casting
- Blow-out proof stem
- Anti-static device (option)
- Locking device
- Tapped & drilled mounting pad
- **API 607 Fire safe approved**
- **ASME B16.34 Wall thickness**
- **NACE MR0175**
- **Seal welded ends**
- **TA-Luft approved (option)**
- **Economic pattern - 2006W**
- Thread type : ASME B1.20.1 (NPT)
DIN2999 & BS21
ISO7/1 & EN10226

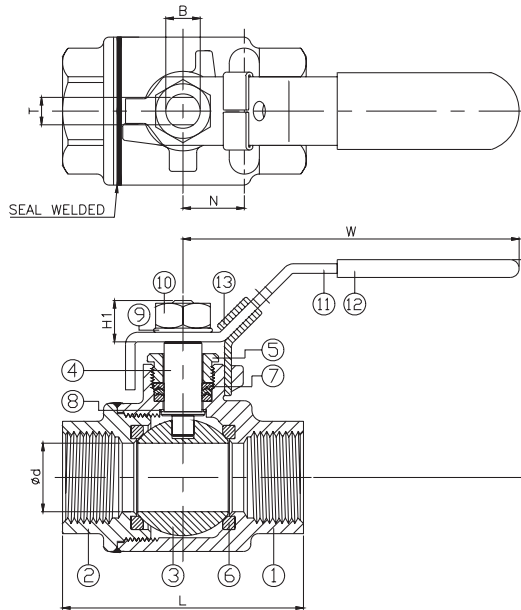

ITEM	PARTS	MATERIAL	
1	BODY	ASTM A351-CF8M	ASTM A216-WCB
2	CAP		
3	BALL	ASTM A351-CF8M	
4	STEM	ASTM A276-316	
5	GLAND NUT	AISI 304	
6	SEAT	PTFE / RTFE	
7	PACKING	GRAPHITE	
8	THRUST WASHER	CTFE	
9	SPRING WASHER		
10	NUT	AISI 304	
11	HANDLE		
12	HANDLE SLEEVE	PVC	
13	LOCKING DEVICE	AISI 304	

- ABOVE MENTIONED MATERIALS APPLY TO FIRE SAFE DESIGN
- TA-LUFT DESIGN SHOULD REPLACE WITH PTFE PACKING

DN	d	L	W	H	H1	B	T	Torque (N-m)	Weight (kg)
8	11.6	60.5	102	53.6	10.5	5/16"	5	5.1	0.4
10	12.8	60.5	102	53.6	10.5	5/16"	5	6.4	0.4
15	15	62.5	102	57	10.5	5/16"	5	6.4	0.4
20	20.2	77	124	62.1	13.5	3/8"	6.5	6.4	0.7
25	25.6	90	165	80	15.7	7/16"	8	11.4	1.3
32	32	100	165	83.7	15.7	7/16"	8	28.6	2
40	38	118	188	99	17	1/2"	9	32.5	2.5
50	50.8	138	188	107	17	1/2"	9	44.2	4.1
65	65.5	167	250	142	27.5	3/4"	12	55	6.4
80	80	193	250	153	27.5	3/4"	12	70	10.9
100	100	258	324	180	34	1"	16	90	21

unit:mm

NPS	d	L	W	H	H1	B	T	Torque (in-lb)	Weight (lb)
1/4"	0.46	2.38	4.02	2.11	0.41	5/16"	0.2	45.1	0.9
3/8"	0.5	2.38	4.02	2.11	0.41	5/16"	0.2	56.6	0.9
1/2"	0.59	2.46	4.02	2.24	0.41	5/16"	0.2	56.6	0.9
3/4"	0.8	3.03	4.88	2.44	0.53	3/8"	0.26	56.6	1.5
1"	1.01	3.54	6.5	3.15	0.62	7/16"	0.31	100.9	2.9
1-1/4"	1.26	3.94	6.5	3.3	0.62	7/16"	0.31	253.1	4.4
1-1/2"	1.5	4.65	7.4	3.9	0.67	1/2"	0.35	287.6	5.5
2"	2	5.43	7.4	4.21	0.67	1/2"	0.35	391.2	9
2-1/2"	2.58	6.57	9.84	5.59	1.08	3/4"	0.47	486.8	14.1
3"	3.15	7.6	9.84	6.02	1.08	3/4"	0.47	619.5	24
4"	3.94	10.16	12.76	7.09	1.34	1"	0.63	796.6	46.3

unit:in



8F., No.201, Sec. 2, Tiding Blvd., Neihu District, Taipei City 114, Taiwan R.O.C.
 TEL : +886-2-2658-5800 FAX : +886-2-2658-2266 / 2799-7766

[Http://www.haitima.com.tw](http://www.haitima.com.tw)
 E-mail : haitima@seed.net.tw