

Smart Solutions. Powerful Products.



Gear Operators

Series GO-24, GO-30, GO-50, GO-80 Worm Gear Operators

FEATURES

- Worm Gear Operators with Torque Output from 1,000 to 18,000 In-Lbs.
- ISO Mounting Patterns on all Sizes
- Output Torque Ratings based on 80 Lbs. of Rim Pull per MSS & API Standards
- Sealed Weathertight Housings
- Unique External Lube Fitting and Built-In Grease Relief Valve
- Epoxy Coated Housings
- Standard NAMUR Pattern for Limit Switch Mounting
- Designed to insure that Over-Torque Failure Point is Handwheel Pin, assuring External Failure
- Multiple Drive Inserts Available. See Page 4

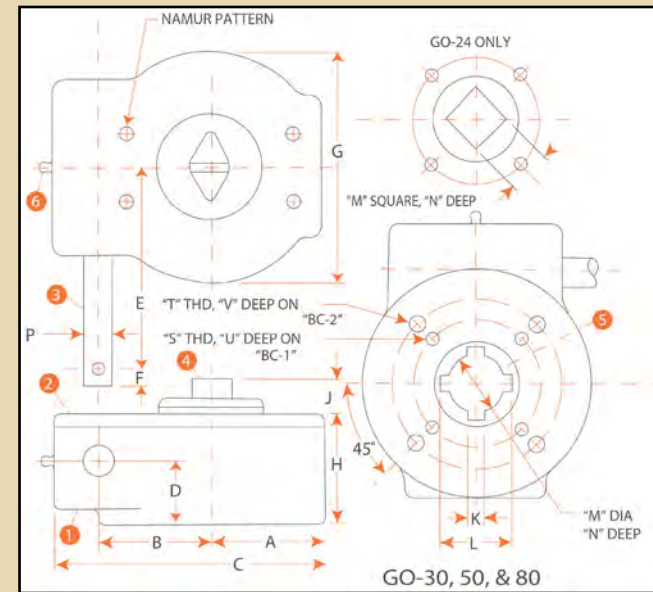
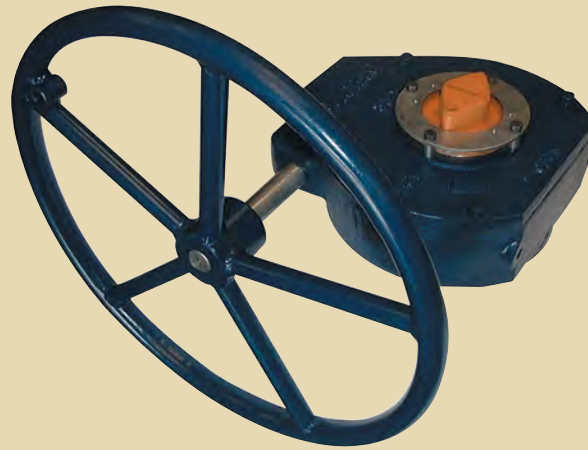

MATERIALS OF CONSTRUCTION

PART	QTY.	DESCRIPTION	STANDARD MATERIAL
1	1	Body	Cast Iron
2	1	Cover	Cast Iron
3	1	Input Shaft	1045 Steel
4	1	Position Indicator	Cast Iron
5	1	Output Shaft	Ductile Iron
6	1	Grease Fitting	Plated Carbon Steel
Not Shown	4	Cover Bolts	Plated Carbon Steel
Not Shown	2	Limit Stop Screws	Alloy Steel

DIMENSIONS

UNIT	A	B	C	D	E	F	G	H	J	K	L
GO-24-11MM	2.13	1.77	5.04	1.50	5.67	.76	4.25	2.52	.87	N/A	N/A
GO-24-14MM	2.13	1.77	5.04	1.50	5.67	.76	4.25	2.52	.87	N/A	N/A
GO-30	3.03	2.48	6.93	1.75	5.40	1.50	6.06	2.95	.87	.190/.193	1.44
GO-50	3.15	3.07	7.48	1.75	5.80	1.50	6.30	2.95	.87	.375/.377	2.30
GO-80	3.94	4.72	10.24	2.17	7.70	1.50	9.85	3.86	1.50	.500/.502	2.71

UNIT	M	N	P DIA	S	T	U	V	BC-1	BC-2	ISO #1	ISO #2	THRU HOLE
GO-24-11MM	11MM	2.40	.63	1/4"-20UNC	5/16"-18UNC	.50	.50	1.97	2.76	F05	F07	.71
GO-24-14MM	14MM	2.40	.63	1/4"-20UNC	5/16"-18UNC	.50	.50	1.97	2.76	F05	F07	.71
GO-30	1.250/1.252	2.00	.79	5/16"-18UNC	3/8"-16UNC	.50	.59	2.76	4.02	F07	F10	1.10
GO-50	1.938/1.940	2.05	.79	1/2"-13UNC	N/A	.87	N/A	4.92	N/A	F12	N/A	1.90
GO-80	2.375/2.377	3.86	.94	5/8"-11UNC	N/A	1.00	N/A	5.51	N/A	F14	N/A	2.38

PERFORMANCE TABLE

OPERATOR	GEAR RATIO	MECHANICAL ADVANTAGE	WEIGHT (LBS.)	MAXIMUM TORQUE RATING (IN-LBS.)	EXTERNAL FAILURE TORQUE (IN-LBS.)	INTERNAL FAILURE TORQUE (IN-LBS.)	OUTPUT TORQUE @ 80 LBS. RIM PULL 6" HANDWHEEL (IN-LBS.)	OUTPUT TORQUE @ 80 LBS. RIM PULL 10" HANDWHEEL (IN-LBS.)	OUTPUT TORQUE @ 80 LBS. RIM PULL 12" HANDWHEEL (IN-LBS.)	OUTPUT TORQUE @ 80 LBS. RIM PULL 18" HANDWHEEL (IN-LBS.)	OUTPUT TORQUE @ 80 LBS. RIM PULL 24" HANDWHEEL (IN-LBS.)
GO-24	24:1	3.4:1	8.4	2500	3100	5900	816	1360	1632	2448	N/A
GO-30	30:1	5.8:1	18.5	6000	7000	9700	N/A	2320	2784	4176	N/A
GO-50	50:1	10.0:1	18.9	10000	12000	15000	N/A	4000	4800	7200	9600
GO-80	80:1	13.1:1	47.5	18000	19950	24500	N/A	N/A	6380	9576	12770

Series GO-300 & GO-700 Spur Gear Reduction Worm Gear Operators

FEATURES

- Spur Gear Reduction Worm Gear Operators with Torque Output from 26,000 to 67,000 In-Lbs.
- ISO Mounting Patterns
- Output Torque Ratings based on 80 Lbs. of Rim Pull per MSS & API Standards
- Sealed Weathertight Housings
- Unique External Lube Fitting and Built-In Grease Relief Valve
- Epoxy Coated Housings
- Standard NAMUR Pattern for Limit Switch Mounting
- Standard Eye-Bolts for Lifting
- Designed to insure that Over-Torque Failure Point is Handwheel Pin, assuring External Failure
- Multiple Drive Inserts Available. See Page 4

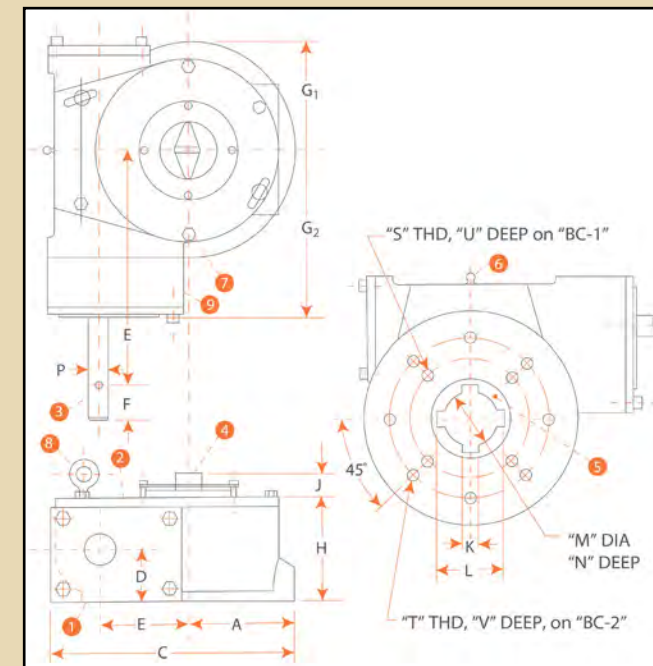

MATERIALS OF CONSTRUCTION

PART	QTY.	DESCRIPTION	STANDARD MATERIAL
1	1	Body	Cast Iron
2	1	Cover	Cast Iron
3	1	Input Shaft	1045 Steel
4	1	Position Indicator	Cast Iron
5	1	Output Shaft	Ductile Iron
6	1	Grease Fitting	Plated Carbon Steel
7	5	Cover Bolts	Plated Carbon Steel
8	2	Eye Bolts	Plated Carbon Steel
9	1	Spur Gear Housing	Cast Iron
Not Shown	2	Limit Stop Screws	Alloy Steel

DIMENSIONS

UNIT	A	B	C	D	E	F	G1	G2	H	J	K	L
GO-300-F14	4.92	4.13	11.42	2.36	11.18	1.50	4.92	7.56	4.2	1.58	.500/.502	2.71
GO-300-F16	4.92	4.13	11.42	2.36	11.18	1.50	4.92	7.56	4.72	1.58	.500/.502	2.71
GO-700	5.91	5.51	13.78	2.76	12.76	1.50	5.91	9.06	5.59	1.58	.750/.753	4.19

UNIT	M	N	P DIA	S	T	U	V	BC-1	BC-2	ISO #1	ISO #2	THRU HOLE
GO-300-F16	2.375/2.377	4.69	.94	5/8"-11UNC	N/A	.94	N/A	5.51	N/A	F14	N/A	2.38
GO-300-F19	2.375/2.377	4.69	.94	3/4"-10UNC	N/A	1.18	N/A	6.50	N/A	F16	N/A	2.38
GO-700	3.750/3.752	5.60	.94	3/4"-10UNC	5/8"-11UNC	1.50	.98	6.50	10.00	F16	F25	3.75

PERFORMANCE TABLE

OPERATOR	GEAR RATIO	MECHANICAL ADVANTAGE	WEIGHT (LBS.)	MAXIMUM TORQUE RATING (IN-LBS.)	EXTERNAL FAILURE TORQUE (IN-LBS.)	INTERNAL FAILURE TORQUE (IN-LBS.)	OUTPUT TORQUE @ 80 LBS. RIM PULL 12" HANDWHEEL (IN-LBS.)	OUTPUT TORQUE @ 80 LBS. RIM PULL 18" HANDWHEEL (IN-LBS.)	OUTPUT TORQUE @ 80 LBS. RIM PULL 24" HANDWHEEL (IN-LBS.)	OUTPUT TORQUE @ 80 LBS. RIM PULL 30" HANDWHEEL (IN-LBS.)	OUTPUT TORQUE @ 80 LBS. RIM PULL 36" HANDWHEEL (IN-LBS.)
GO-300	290:1	50.0:1	81.4	40,000	50,000	65,000	24,000	26,000	N/A	N/A	N/A
GO-700	320:1	46.7:1	140.8	68,000	70,000	80,000	22,416	33,624	44,832	56,040	67,248

How to Order Quadrant Gear Operators

GO50 - F14 - 27MM - 18

GEAR OPERATOR

GO24
GO30
GO50
GO80
GO300
GO700

ISO PATTERN

F05/F07 = GO24
F07/F10 = GO30
F12 = GO50
F14 = GO80 OR GO300
F16 = GO300
F16/F25 = GO700

FINAL DRIVE

Blank = Keyed Per Dimension Charts (Pgs. 2 & 3)
11MM = 11MM Square (GO24)
14MM = 14MM Square (GO24)
17MM = 17MM Square (GO30)
19MM = 19MM Square (GO30)
22MM = 22MM Square (GO50)
27MM = 27MM Square (GO50 or 80)
10MM DIA = 10MM Thru Hole (GO30 or 50)
25MM DIA = 25MM Thru Hole (GO80, 300, 700)

HANDWHEEL

BS = None
6 = 6" OD (GO24)
10 = 10" OD (GO 24 OR 30)
12 = 12" OD (All)
18 = 18" OD (All)
20 = 20" OD (GO80, 300, 700)
24 = 24" OD (GO80 & 700)
30 = 30" OD (GO700)
36 = 36" OD (GO700)

INSERT DIMENSIONS

INSERT	FOR:	A DIA.	B	C	D DIA.	E	F	G DIA.	H	J	K	L	M	R
GO30-10MMDIA	GO-30	1.248/1.244	.39 DIA	1.335	N/A	N/A	N/A	N/A	2.00	N/A	.187/.185	N/A	N/A	N/A
GO30-17MMSQ	GO-30	1.248/1.244	.669/.674	1.335	N/A	N/A	N/A	N/A	2.00	N/A	.187/.185	N/A	N/A	.920
GO30-19MMSQ	GO-30	1.248/1.244	.748/.753	1.335	N/A	N/A	N/A	N/A	2.00	N/A	.187/.185	N/A	N/A	.995
GO50-10MMDIA	GO-50	1.936/1.930	.39 DIA	2.276	N/A	N/A	N/A	N/A	2.00	N/A	.375/.373	N/A	N/A	N/A
GO50-22MMSQ	GO-50	1.936/1.930	.866/.871	2.276	N/A	N/A	N/A	N/A	2.00	N/A	.375/.373	N/A	N/A	1.120
GO50-27MMSQ	GO-50	1.936/1.930	1.063/1.068	2.276	N/A	N/A	N/A	N/A	2.00	N/A	.375/.373	N/A	N/A	1.425
GO80-25MMDIA	GO-80 & 300	2.374/2.371	N/A	N/A	.985	2.156	2.457	2.600	2.95	N/A	.500/.502	N/A	.16	N/A
GO80-27MMSQ	GO-80 & 300	2.374/2.371	1.063/1.068	N/A	N/A	2.156	2.457	2.600	2.95	N/A	.500/.502	N/A	.16	1.425
GO80-33DIA	GO-80 & 300	2.374/2.371	N/A	N/A	1.313/1.315	2.156	2.457	2.600	2.95	1.455	.500/.502	.313/.315	.16	N/A
GO80-38DIA	GO-80 & 300	2.374/2.371	N/A	N/A	1.500/1.502	2.156	2.457	2.600	2.95	1.670	.500/.502	.375/.377	.16	N/A
GO80-41DIA	GO-80 & 300	2.374/2.371	N/A	N/A	1.625/1.628	2.156	2.457	2.600	2.95	1.796	.500/.502	.375/.377	.16	N/A
GO700-25MMDIA	GO-700	3.748/3.745	N/A	N/A	.985	3.462	3.839	4.020	3.15	N/A	.750/.752	N/A	.16	N/A
GO700-51DIA	GO-700	3.748/3.745	N/A	N/A	2.000/2.003	3.462	3.839	4.020	3.15	2.223	.750/.752	.500/.502	.16	N/A
GO700-63DIA	GO-700	3.748/3.745	N/A	N/A	2.500/2.503	3.462	3.839	4.020	3.15	2.815	.750/.752	.708/.710	.16	N/A

HANDWHEEL DIMENSIONS

PART NUMBER	FOR:	A DIA.	B	C	D DIA.	E	F	WEIGHT LBS
GO24-6	GO-24	6.0	2.5	1.1	.63	.32	.20	3.0
GO24-10	GO-24	10.0	2.9	1.9	.63	.40	.20	6.6
GO24-12	GO-24	12.0	2.9	1.9	.63	.40	.20	7.0
GO24-18	GO-24	18.0	2.2	2.3	.63	.79	.20	7.5
GO30-10	GO-30 & 50	10.0	2.9	1.9	.79	.40	.20	6.6
GO30-12	GO-30 & 50	12.0	2.9	1.9	.79	.40	.20	7.0
GO30-18	GO-30 & 50	18.0	6.2	2.3	.79	.79	.20	7.5
GO80-12	GO-80, 300, 700	12.0	2.9	1.9	.95	.40	.24	7.0
GO80-18	GO-80, 300, 700	18.0	2.2	2.3	.95	.79	.24	7.5
GO80-20	GO-80, 300, 700	20.0	6.7	2.3	.95	.79	.24	8.4
GO80-24	GO-80 & 700	24.0	6.9	2.3	.95	.79	.24	9.7
GO80-30	GO-700	30.0	8.3	2.3	.95	.79	.24	12.3
GO80-36	GO-700	36.0	9.7	2.3	.95	.79	.24	15.8

